

User Guide

LED Double Dimmer 2x100W

Item NO.: D604U

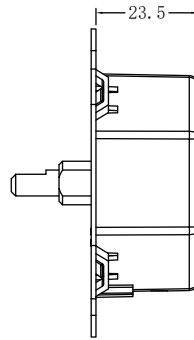
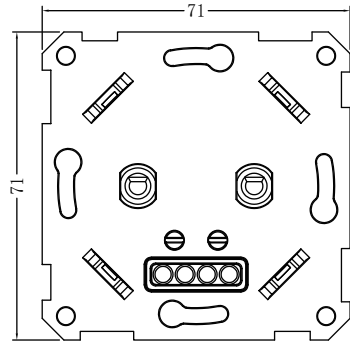
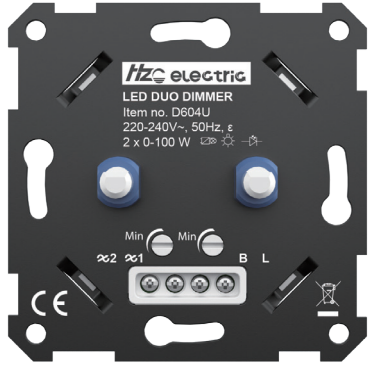

- ① Light off memory
- ② Over current protection
- ③ Over-temperaure protection

1. Technical Data

Model No.	D604U	
Description	LED Double Dimmer 2x100W	
Input Voltage	220-240V	
Input frequency	50Hz	
Load	LED	
	Incandescent	2 x 0-100W
	Halogen	
Dimming mode	Trailing edge	
Control Way	Multiway	
Material	Heatsink	Aluminum
	Bottom Case	PC
Color	White	
Weight(g)	52.8	
Dimension(mm)	71*71*43mm	

2. Dimmer wiring diagram

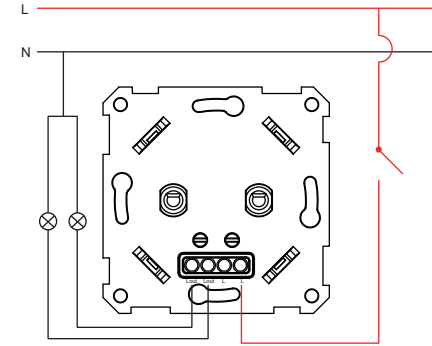

3. Features

Setting min. light level

Turn on the lights using the dimmer shaft, Then turn the dimmer shaft as far as possible to the left (minimum light output). If the lights blink, use a screwdriver to turn the MIN potentiometer slowly to the right for stable light, Is the light already stable? Then slowly turn the MIN to the left for even better dimmability, until just before the point where the lamps start flashing. That is the best dimmability of these LED lamps, You can set this for both light groups.

Turn off the lights memory

1. Turn on the dimmer and adjust it to any brightness level
2. After adjusting the brightness, turn off the dimmer and wait for two seconds before turning it back on

4. WARNING

- Installation must be carried by a qualified electrician.
- Before installation, please check whether it conforms to local electric standards
- Power supply must be turn off when install and clean the dimmer.
Wipe the surface dust or dirt with soft cloth or tissue, do not use the detergent or other corrosive chemical solution.
- Please place and protect the cover properly when it' s in installation to avoid the damage.
- There is no strong impact, vibration, electromagnetic field interference, corrosion, or dusty gas around the usage environment
- The product should avoid frost, condensation, water seepage, rain, etc.